

# LARGE RANGE DIGITAL RADIUS GAGE

ATTENTION:  
NO DATA OUTPUT

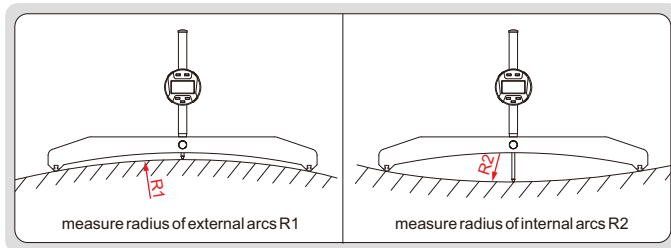
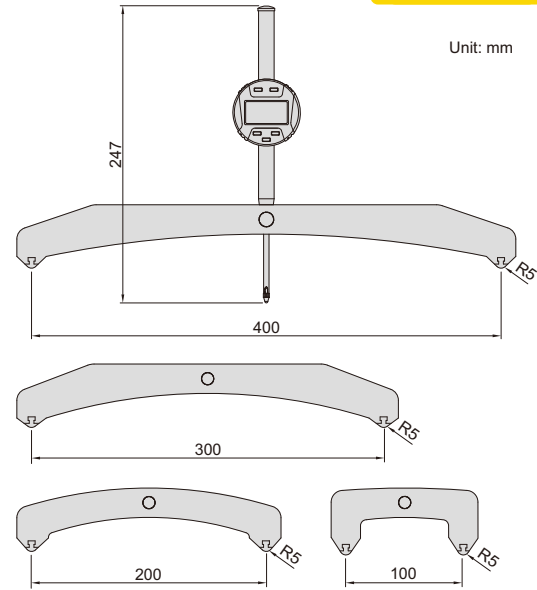

- Measure radius of internal or external arcs
- Resolution: 0.01mm/0.001"
- Buttons: on/off, hold, mm/inch, s (select jaws), zero
- Display can be rotated by 320°
- Supplied with 4 jaws for different sizes of arc
- Battery CR2032, automatic power off (time is adjustable)

Code	Range of external radius (R1)	Range of internal radius (R2)	Accuracy (mm)
2197	100-15000mm/4-590"	100-15000mm/4-590"	±0.005R*

\* R is the radius to be measured. For example, radius is 100mm, the accuracy is  $\pm 0.005 \times 100 = \pm 0.5\text{mm}$